

HL660/2

Rain hopper DN110/125 with leaf strainer, adapter rings d 75-110mm and frost-proof flap seal



Minimax-rain hopper DN110/125 with leaf strainer, adapter rings d 75 - 110 mm and frost- and drought-proof flap seal



techn. drawing

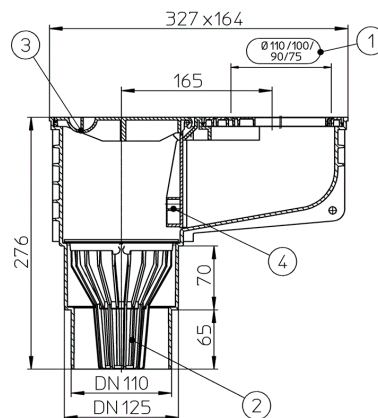

MAIN DATA

spare parts



HL0600.1E
adapter rings d 75, 90, 100 and 110mm



HL0600.2E
leaf strainer



HL0600.3E
cleaning eye



HL0600.4E
flap



HL0600.8E
adapter ring d 120mm

attachment



HL0600.0E
adapter rings for cast iron pipes



HL0600.5E
adapter ring squared 80-100mm



HL0600.7E
adapter ring d 80mm



HL0600.8E
adapter ring d 120mm



HL601
extension 50mm

Alternatives



HL660/2-80
Rain hopper DN110/125 with leaf strainer, adapter rings d 80mm and frost-proof flap seal

Extensions



HL601
extension 50mm

TECHNICAL DATA

material	PP	installation height	180 mm
dimension	DN110/125	grate frame	
capacity	6,67 l/s	grate	
weight	0,8	load class	
EAN	9003076011902	inlet	
		standards	

PACKAGING DATA

carton

unit	1 [pcs.]
weight	1,04 [kg]
EAN/pack.	9003076011902
height/width/depth	170/280/330 [mm]
volume	0,015708 [m³]

single use pallet

unit	132 [pcs.]
weight	157 [kg]
EAN/pack.	
height/width/depth	2100/1000/1300 [mm]
volume	2,73 [m ³]