

==> Fließrichtung ==> Direction of flow ==>

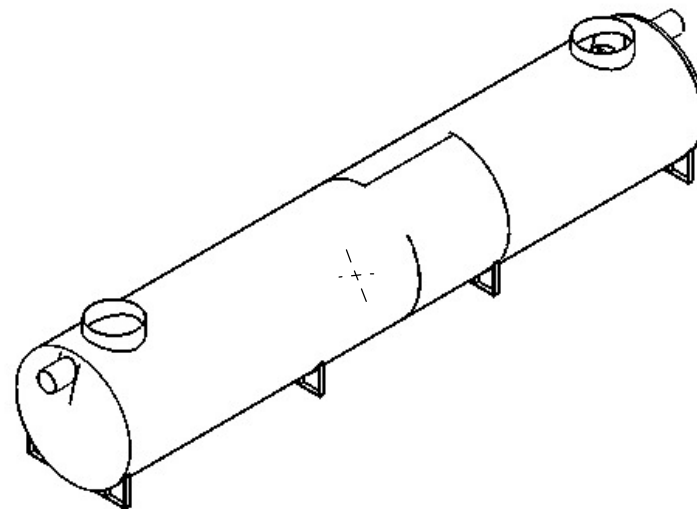
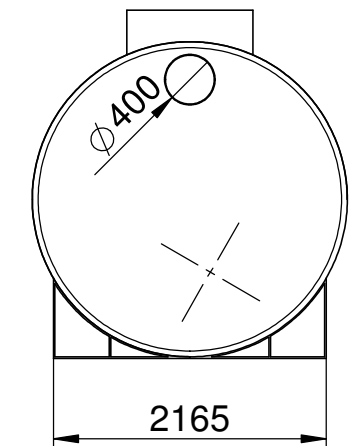
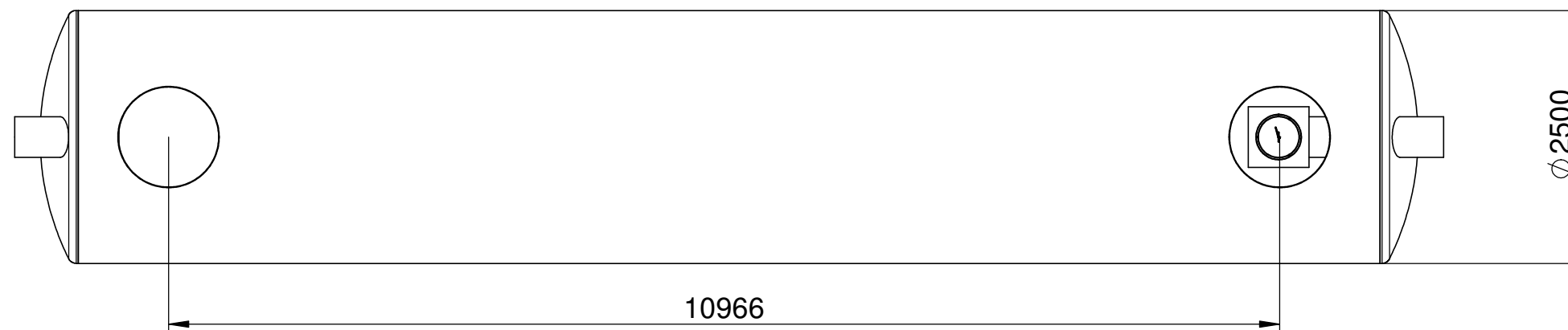
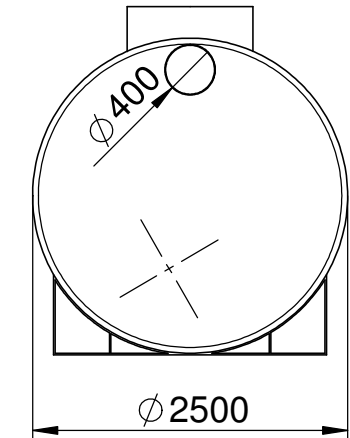
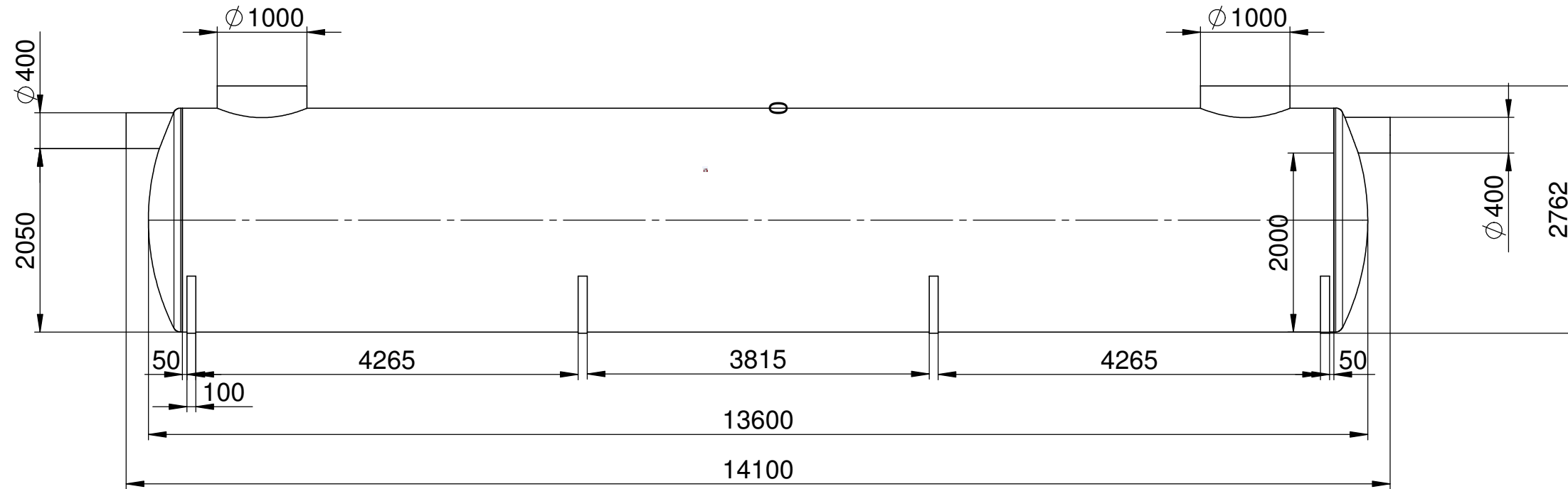

Hauraton GmbH & CO KG Werkstraße 13		D-76437 Rastatt Germany		hauraton	
Typ / Type	NG/NS/Flow rate	Ref.	SKG		
1	250 l/s	Serie # Serial #	181250		
EN858 Koaleszenzabscheider / Oil separator					
Abscheiderinhalt	26950	l	Capacity separator		
Schlammfanginhalt	28270	l	Capacity sludge trap		
Speichermenge LF	4197	l	Storage hydrocarbons		
Schichtdicke	300	mm	Thickness layer hydrocarbons		
Herstellungsjahr	20XX		Manufacturing year		

hauraton		Bezeichnung AF - SKGXX - NG 250 Modell 2017			
Werkstraße 13 76437 Rastatt Germany		Tel. +49 (0) 72 22 9 58-0 Fax +49 (0) 72 22 9 58-100 info@hauraton.com		Sub of	
Tolerierung nach DIN ISO 8015		Allgemeintoleranzen nach DIN ISO 2768-c		© Hauraton 2016 Copyright nach ISO 16016	
DIN ISO 5456-2		Datum		Artikel-Nr.	
Zeichnungs-Bearbeitung		04.07.2017		IAN	
Status		Name		Modell 0000087329	
00		00		V8	
Revision (M)		Revision (Z)		Zeichnung 0000096978	
Änderungen		CAD-Gewicht		V2	
		6694634 g		Blatt 1	
		CAD-Volumen		von 1	
		2472658 cm ³		Maßstab 1:100	
		Werkstoff		Format DIN A3	
		Werkstoff-Detail			